



GUIDE FOR THE

CERTIFICATION OF OFFSHORE MOORING CHAIN

DECEMBER 2009 (Updated February 2014 – see next page)

**American Bureau of Shipping
Incorporated by Act of Legislature of
the State of New York 1862**

**Copyright © 2009
American Bureau of Shipping
ABS Plaza
16855 Northchase Drive
Houston, TX 77060 USA**

Updates

February 2014 consolidation includes:

- December 2009 version plus Corrigenda/Editorials

Foreword

This is the third edition of the *Guide for the Certification of Offshore Mooring Chain*, following from the 1986 and 1999 versions.

This new version adds two higher strength grades R4S and R5 (the previous Q identification letter has been dropped) to the existing R3, R3S, and R4 and addresses studded and studless flash butt welded chain, chafing chain, chain accessories, and special subsea connectors.

The Guide includes additional requirements for the qualification of manufacturers, especially with respect to forged and cast accessories, and has defined certain aspects of manufacturing controls more comprehensively.

This Guide supersedes previous versions and ABS encourages its immediate application. Compliance with this edition is required for offshore mooring chain and accessories with a date of purchase order of the materials on or after 1 July 2011.



GUIDE FOR THE CERTIFICATION OF OFFSHORE MOORING CHAIN

CONTENTS

SECTION 1	General Requirements	1
1	Scope	1
1.1	Application	1
1.3	Mooring Equipment.....	1
1.5	Studless Chain	1
1.7	Chafing Chain.....	1
1.9	Special Subsea Mooring Connectors.....	1
3	Chain and Accessory Grades	1
3.1	R3, R3S, R4, R4S, and R5	1
3.3	R4S and R5.....	1
3.5	Approval	2
5	Chain Manufacturer Approval	2
5.1	Approval of Chain Manufacturers	2
5.3	Manufacturing Process Approval	3
5.5	CTOD Tests (Crack Tip Opening Displacement Tests)	3
5.7	Furnace Calibration	4
5.9	R4S and R5 Additional Requirements	4
5.11	Qualification Testing	4
7	Approval of Quality Systems at Chain Manufacturers	6
7.1	Quality Provision.....	6
7.3	Procedures for Obtaining Approval.....	6
7.5	Quality Assurance Certificate	7
7.7	Test Data and Documentation	7
9	Approval of Steel Mills – Rolled Bar and Plate for Chain and Accessories.....	7
9.1	Bar and Plate Material for Chain and Accessories, Including Pins.....	7
9.3	Approval Restrictions.....	8
9.5	Chemical Composition.....	8
9.7	Heat Treatment Sensitivity Study for Rolled Bars	8
9.9	Strain Aging, Temper Embrittlement, Hydrogen Embrittlement	8
11	Accessory Manufacturer Approval.....	8
11.1	Approval of Forges and Foundries – Accessories	8
11.3	Approval Restrictions.....	8
11.5	Forging Reduction Ratio	8
11.7	Chemical Composition.....	9
11.9	Strain Aging, Temper Embrittlement, Hydrogen Embrittlement	9

11.11	Heat Treatment Sensitivity Study	9
11.13	CTOD Tests (Crack Tip Opening Displacement Tests).....	9
11.15	Furnace Calibration	9
11.17	R4S and R5 Additional Requirements.....	9
11.19	Manufacturing Process Approval.....	10
11.21	Qualification Testing.....	10
13	Approval of Quality Systems at Accessory Manufacturers	11
13.1	Quality Provision	11
13.3	Procedures for Obtaining Approval	12
13.5	Quality Assurance Certificate	12
13.7	Test Data and Documentation.....	13

TABLE 1	Mechanical Properties of Offshore Mooring Chain and Accessories.....	2
---------	--	---

SECTION 2 Material Requirements for Chain and Accessories..... 14

1	Scope	14
3	Rolled Steel Bars	14
3.1	Steel Bar Manufacture.....	14
3.3	Chemical Composition	14
3.5	Mechanical Tests	14
3.7	Dimensional Tolerances.....	16
3.9	Nondestructive Examination and Repair	17
3.11	Marking.....	17
3.13	Heat Treatment of Rolled Bars Intended for Accessory Pins.....	17
5	Forged Steel	17
5.1	Forged Steel Accessories.....	17
5.3	Chemical Composition	18
5.5	Heat Treatment	18
5.7	Mechanical Properties.....	18
5.9	Mechanical Tests	18
5.11	Nondestructive Examination.....	19
5.13	Marking.....	19
7	Cast Steel	19
7.1	Cast Steel Accessories	19
7.3	Chemical Composition	19
7.5	Heat Treatment	20
7.7	Mechanical Properties.....	20
7.9	Mechanical Tests	20
7.11	Nondestructive Examination.....	20
7.13	Marking.....	21
9	Materials for Studs	21

TABLE 1	Dimensional Tolerance of Bar Stock.....	16
---------	---	----

FIGURE 1	Sampling for Tension Specimens and Charpy V-Notch Specimens Steel Bars, Forgings and Castings	16
----------	---	----

SECTION 3	Design and Manufacture of Chain and Accessories	22
1	Design	22
1.1	Design Details	22
1.3	Stud Link Chain	22
1.5	Kenter Shackles.....	22
1.7	Special Subsea Mooring Connectors.....	22
1.9	Ancillary Accessory Components	22
3	Chain Cable Manufacturing Process	22
3.1	Joining Shackles and Splice Links.....	22
5	Chain Cable Manufacturing Process Records.....	23
5.1	Bar Heating.....	23
5.3	Flash Welding of Chain Cable	23
5.5	Heat Treatment of Chain Cable	23
7	Mechanical Properties	23
9	Proof and Breaking Test Loads	23
11	Freedom from Defects	23
13	Dimensions and Dimensional Tolerances	25
13.1	Link Shape and Proportion	25
13.3	Tolerances Applicable to Chain Links.....	25
15	Stud Link Chain – Welding of Studs	27
15.1	Heat Treatment of Welded Studs.....	27
15.3	Extent of Stud Weld	27
15.5	Single Weld	27
15.7	Weld Procedure – Studs.....	28
15.9	Fillet Size.....	28
15.11	Weld Quality	28
15.13	Stud Weld Inspection.....	28
17	Connecting Common Links (Splice Links).....	28
17.1	Procedure Approval	28
17.3	Adjacent Links to Splice Links	28
17.5	Testing and Inspection.....	28
17.7	Identification	28
TABLE 1	Formulas for Proof and Break Test Loads, Weight, and 5-Link Length	24
FIGURE 1	Test Sample Locations in Link	24
FIGURE 2A	Proportions, Dimensions and Tolerances of Stud Link Common Link	26
FIGURE 2B	Proportions, Dimensions and Tolerances of Studless Common Link	27
SECTION 4	Testing and Inspection of Finished Chain	29
1	General	29
3	Proof and Break Load Tests	29
3.1	Proof Load Test	29
3.3	Break Test Specimens.....	29

5	Dimensions and Dimensional Tolerances	30
5.1	Individual Link Measurement – After Proof Load	30
5.3	Five-Link Measurement – After Proof Load	30
7	Mechanical Tests on Completed Chain – After Proof Load.....	30
7.1	Specified Tests	30
7.3	Test Frequency and Properties	31
7.5	Frequency of Crown Impact Tests.....	31
9	Nondestructive Examination – After Proof Load Test.....	31
9.1	Visual Inspection	31
9.3	Nondestructive Examination – General	31
9.5	Magnetic Particle Inspection (MPI).....	31
9.7	Ultrasonic Testing (UT).....	31
11	Retest, Rejection and Repair Criteria	32
11.1	Measurement of Five Links	32
11.3	Replacement of Defective Links	32
11.5	Surface Defects	32
11.7	Volumetric Defects	32
11.9	Geometrical or Tolerance Failure	32
11.11	Break Load Test Failure	32
11.13	Proof Load Test Failure	33
11.15	Tensile Test Failure	33
11.17	Charpy Test Failure	33
13	Marking	33
13.1	Locations for Marking of Chain.....	33
13.3	Markings.....	34
13.5	Chain Certificate.....	34
15	Manufacturer’s Documentation	34
TABLE 1	Frequency of Break and Mechanical Tests	30

SECTION 5	Testing and Inspection of Accessories.....	35
1	General	35
1.1	Accessory Manufacturing Process	35
1.3	Accessory Manufacturing Process Records	35
3	Proof and Break Load Tests	35
3.1	Proof Load Test.....	35
3.3	Break Load Test.....	35
3.5	Definition of a Batch	35
3.7	Accessories Subjected to Break Test.....	36
3.9	Over-Designed Accessories	36
5	Dimensions and Dimensional Tolerances	36
5.1	Dimensional Tolerances	36
7	Mechanical Tests	36
7.1	Test Location of Forged Shackles	36
7.3	Test Location of Cast Shackles	36
7.5	Complex Geometry Accessories	37
7.7	Individual Accessories or Small Batches	37

	7.9	Definition of a Batch.....	37
	7.11	Test Location of Pins	37
9		Nondestructive Examination – After Proof Load Test.....	38
	9.1	Visual and Surface Examination	38
	9.3	Nondestructive Examination – General	38
	9.5	Manufacturer’s Statement.....	38
11		Test Failures	38
13		Marking and Certification	39
	13.1	Marking.....	39
	13.3	Certificates.....	39
15		Documentation.....	39
FIGURE 1 Pin Heat Treatment Buffer			37



SECTION 1 General Requirements

1 Scope

1.1 Application

This Guide supersedes previous versions and ABS encourages its immediate application. Compliance with this edition is required for offshore mooring chain and accessories with a date of purchase order of the materials on or after 1 July 2011.

These requirements apply to the materials, design, manufacture, and testing of offshore mooring chain and accessories intended to be used for temporary and permanent applications such as: mooring of mobile offshore units, mooring of floating production units, mooring of offshore loading systems, and mooring of gravity based structures during fabrication.

1.3 Mooring Equipment

Mooring equipment covered is common stud and studless links, connecting common links (splice links), enlarged links, end links, detachable connecting links (shackles), end shackles, double pinned H-type links, tri-plates and shackles, and H-links specifically designed for chain to wire/polyester rope connections.

Mooring foundation shackles and anchor shackles for mooring are also to comply with the requirements of this Guide.

In addition, accessories specifically designed for temporary applications, such as pear links, Kenter shackles, swivels and swivel shackles, and similar designs are covered.

1.5 Studless Chain

Studless link chain is normally deployed only once, being intended for long-term permanent mooring systems with pre-determined design life.

1.7 Chafing Chain

Requirements for chafing chain for single point mooring arrangements are given in 3-5-1/17 of the *ABS Rules for Building and Classing Steel Vessels*. In addition, recognized industry standards such as OCIMF may be applied.

1.9 Special Subsea Mooring Connectors

In the case of specially designed subsea connectors, these requirements are in general applicable. However, consideration will be given to unique designs, validated by first principles engineering, with mechanical and material properties different from those herein.

3 Chain and Accessory Grades

3.1 R3, R3S, R4, R4S, and R5

Depending on the nominal tensile strength of the steels used for manufacture, chains are to be subdivided into five grades (i.e., R3, R3S, R4, R4S, and R5). Refer to Section 1, Table 1 below for mechanical properties.

3.3 R4S and R5

Specifications for R4S and R5 are newly introduced into this Guide and therefore more detailed information regarding design, manufacture, testing, and specification details are to be submitted to ABS.

3.5 Approval

Each grade of chain or accessory is to be individually approved. Approval for a higher grade does not constitute approval of a lower grade. Approved manufacturers will be included in the list of ABS Approved Manufacturers on the ABS website. The approval will indicate the Company, grade, product, maximum size, and any limitations.

TABLE 1
Mechanical Properties of Offshore Mooring Chain and Accessories

Grade	Yield Strength ⁽¹⁾ minimum N/mm ² (kg/mm ² , ksi)	Tensile Strength ⁽¹⁾ minimum N/mm ² (kg/mm ² , ksi)	Elongation in 5D minimum in percent	Reduction of Area minimum in percent ⁽³⁾	Charpy V-Notch impact Tests Energy in Joules Minimum Average		
					Temp. °C ⁽²⁾	Average for Base Metal	Average at Flash Weld
R3	410 (42, 59)	690 (70, 100)	17	50	0 -20	60 40	50 30
R3S	490 (50, 71)	770 (78, 112)	15 ⁽⁵⁾	50 ⁽⁵⁾	0 -20	65 45	53 33
R4	580 (59, 84)	860 (87, 125)	12 ⁽⁵⁾	50 ⁽⁵⁾	-20	50	36
R4S ⁽⁴⁾	700 (71, 101)	960 (98, 139)	12 ⁽⁵⁾	50 ⁽⁵⁾	-20	56	40
R5 ⁽⁴⁾	760 (77, 110)	1000 (102, 145)	12 ⁽⁵⁾	50 ⁽⁵⁾	-20	58	42

Notes

- 1 Aim value of yield to tensile ratio: 0.92 maximum.
- 2 At the option of ABS, the impact test of Grade R3 and R3S may be carried out at either 0°C or minus 20°C to meet the indicated values. It is not required to Charpy test at both temperatures.
- 3 Reduction of area of cast steel accessories is to be for Grades R3 and R3S: minimum 40%; for Grades R4, R4S, and R5: minimum 35%.
- 4 Surface hardness tests are required for R4S and R5 chain and accessories. The target maximum hardness for R4S is HB330 and for R5 is HB340. Two hardness tests at each end 180° apart of chain links or accessories are to be taken.
- 5 For chain cross-weld tensile tests, these properties are to be reported for information only; the stated requirements do not apply.

5 Chain Manufacturer Approval

5.1 Approval of Chain Manufacturers

Offshore mooring chains are to be manufactured only by works approved by ABS. For this purpose, approval tests are to be carried out, the scope of which is to include proof and breaking load tests, measurements, and mechanical tests, including fracture mechanics tests. Approval will be given only after successful testing of the completed chain. The approval for each grade will normally be limited up to the maximum chain diameter tested.

Chain manufacturers are to have a documented and effective quality system approved by ABS. The provision of such a quality system is required in addition to, and not in lieu of, the witnessing of tests by a Surveyor as specified in Sections 2 to 5 of these requirements.

5.3 Manufacturing Process Approval

Manufacturers are to submit for review and approval the sequence of operations from receiving inspection to shipment, including details of the following manufacturing processes:

- i) Bar heating and bending, including method, temperatures, temperature control, recording, and in-process bar identification
- ii) Flash welding, including current, force, time, and dimensional variables, as well as control and recording of parameters
- iii) Flash removal, including method and inspection
- iv) Stud insertion (for stud link chain) method, imprint, and degree of plastic deformation after heat treatment. Stud welding (if applicable)
- v) Heat treatment, including furnace types, means of specifying, controlling and recording of temperature, chain speed and allowable limits, quenching bath and agitation, and cooling method after exit. Procedures, practices, temperatures and limits, heating and cooling rates.
- vi) Proof and break loading, including method, machine, means of horizontal support (if applicable), method of measurement, and recording
- vii) Nondestructive examination procedures
- viii) The manufacturer's surface quality requirement of mooring components
- ix) Connecting common link (splice link) procedures

5.5 CTOD Tests (Crack Tip Opening Displacement Tests)

For initial approval, CTOD tests are to be carried out on the particular ABS mooring grade of material. CTOD tests are to be carried out in accordance with a recognized standard such as BS 7448 Parts 1 & 2. The CTOD test piece is to be a standard 2 × 1 single edge notched bend piece, test location as shown below. The minimum test piece size shall be 50 × 25 mm for chain diameters less than 120 mm, and 80 × 40 mm for diameters 120 mm and above. CTOD specimens are to be taken from both the side of the link containing the weld and from the opposite side. Three links are to be selected for testing, giving a total of six specimens. The tests are to be taken at minus 20°C and meet the minimum values indicated below:

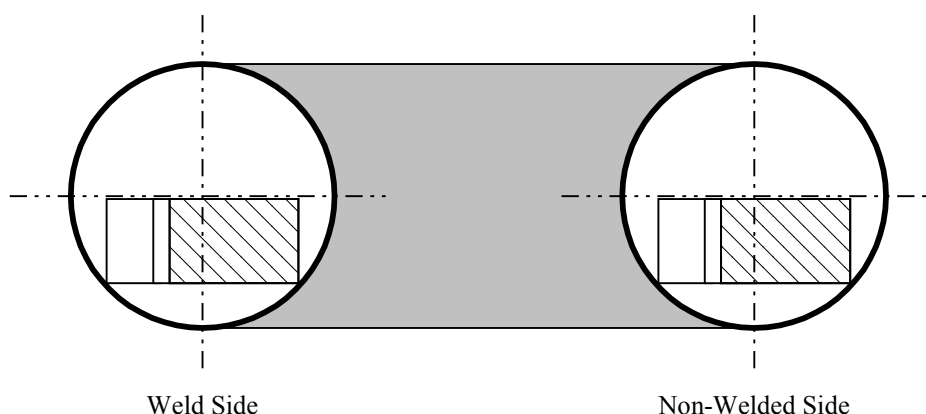

Chain Type	R3 in mm		R3S in mm		R4 in mm		R4S & R5 in mm	
	BM	FBW	BM	FBW	BM	FBW	BM	FBW
Stud link	0.20	0.10	0.22	0.11	0.24	0.12	0.26	0.13
Studless	0.20	0.14	0.22	0.15	0.24	0.16	0.26	0.17

BM = Base Metal

FBW = Flash Butt Weld

5.7 Furnace Calibration

Calibration of furnaces shall be verified by measurement and recording of temperature (surface and internal), using a calibration test piece with dimensions equivalent to the maximum size of link manufactured. Thermocouples are to be placed both on the surface and in a drilled hole located to the mid-thickness position of the calibration block.

Evidence of furnace surveys and calibration is to be provided.

5.9 R4S and R5 Additional Requirements

For R4S and R5 chain, prior to approval, the manufacturer is to have undertaken experimental tests or have relevant supporting data to develop the chain material. The tests and data are to include:

- Fatigue tests, hot ductility tests (no internal flaws are to develop whilst bending in the link forming temperature range)
- Welding parameter research
- Heat treatment study
- Strain age resistance
- Temper embrittlement study
- Stress corrosion cracking (SCC) data
- Hydrogen embrittlement (HE) study, using slow strain test pieces in hydrated environments

Reports indicating the results of experimental tests are to be submitted.

5.11 Qualification Testing

Qualification testing is to include, as a minimum, the tests and examinations on the largest diameter product for each grade for which approval is requested. All proof tests, break tests, and mechanical tests (tension and impact) are to be witnessed by the Surveyor. In addition, hardness distribution and CTOD tests (1/5.5) are to be done but need not be witnessed by the Surveyor. All tests are to be performed on a product that has been subjected to the final heat treatment. Mechanical tests are to be taken from a proof loaded product. Where plastic straining of heat treated chain is used to set studs or stretch chain, appropriate tensile and impact data are to be provided to demonstrate that chain properties are not significantly degraded by the extent of plastic deformation used. Other tests such as hot ductility (creasing), corrosion tests, fatigue tests, and stress corrosion cracking, provide useful information about the characteristics of the chain and such supporting data is to be submitted.

5.11.1 Chemical Analyses

Both ladle and product analyses are to be provided, and are to include carbon, manganese, silicon, phosphorous, sulfur, and all other intentionally added elements. Restrictions on residual elements are also to be submitted.

5.11.2 Proof Load and Break Load Test

Chains are to withstand the proof loads given in Section 3, Table 1, in accordance with 4/3.1 and 4/3.3.

5.11.3 Mechanical Tests

Tension and Charpy tests are to be carried out in accordance with 2/3.5.3 to meet the requirements of Section 1, Table 1.

- Tension Test (Two links are to be tested).* Two tension tests from each link are to be conducted, one clear of the flash weld and the other at the center of the flash weld.
- Charpy V-Notch (CVN) Impact Test.* Three sets of CVN specimens are to be tested from four links. One set is to be taken clear of the weld in the un-deformed region of the link, one set is to be taken from the crown, and one set is to be taken with the root of the notches in the center of the flash weld.

5.11.4 Hardness Tests

Hardness distribution is to be determined across a diameter using Vickers or Rockwell indentors. A diagram showing the hardness distribution is to be submitted.

5.11.5 Stud Welding Qualification

The procedure for fillet welding the stud (if used) is to be qualified in accordance with Chapter 4 of the *ABS Rules for Materials and Welding (Part 2)*, or with another recognized code. All welder qualifications are to be reviewed by the Surveyor.

5.11.6 Microexamination

Microspecimens are to be taken showing the:

- Flash weld, at the surface, at the two-thirds radius and at the mid-thickness
- Base metal, at the surface, at the two-thirds radius and at the mid-thickness
- Stud indentation radius (for stud link only)

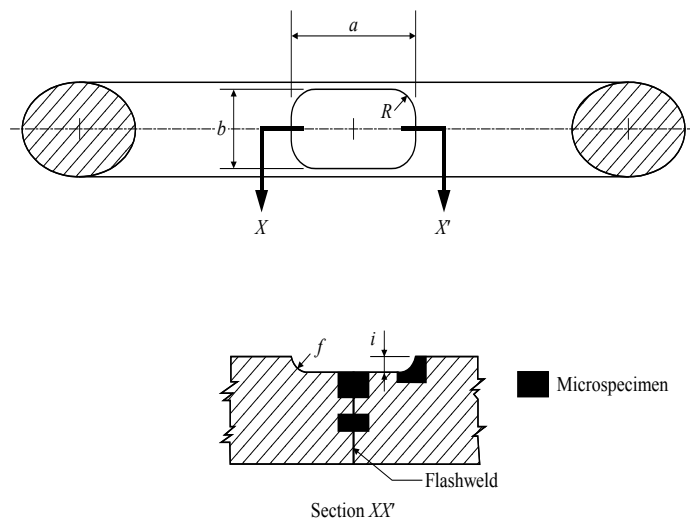

$i =$ typically $0.02d$ to $0.06d$, where d is the nominal diameter

The microspecimens are to be etched with a suitable etchant and photographed at 100X and 500X magnifications. Austenitic and ferritic grain sizes are to be determined and reported. Austenitic grain size is to be number 6 or finer, in accordance with ASTM E112.

Stud imprint and depth are to be measured and recorded

5.11.7 Macroexamination

Two macrospecimens are to be taken at:

- A link longitudinal section at the flash welded side showing the stud indentation area (for stud link only)
- The cross section at both crowns
- The centerline section showing the flash weld, stud indentation depth and radius (if applicable), and stud weld (if applicable)

Macrosections are to be etched. A 10X examination of the entire stud indentation area is to be conducted and reported to verify freedom from cracks, laps or surface imperfections. The macrospecimens are to be photographed at 1X.

7 Approval of Quality Systems at Chain Manufacturers

7.1 Quality Provision

Chain manufacturers are to have a documented and effective quality system that meets ABS requirements. The provision of such a quality system is required in addition to, and not in lieu of, the witnessing of tests by a Surveyor as specified in Sections 2 to 5 of this Guide.

7.1.1 Quality System – General

The manufacturer is to have a documented, effective quality system to ISO 9001 that addresses the following:

- Management structure
- Corporate policies regarding quality
- Internal auditing practices
- Calibration practices for tools, gauges, thermocouples, etc.
- Receiving, in process and pre-delivery, inspection practice
- Testing practices
- Procedures for handling discrepant material
- Marking
- Storage
- Record retention

7.1.2 Manual of Quality System

The manufacturer is to submit details of the quality system employed at the plant in the form of a manual. The effectiveness of the system is to be verified by the Surveyor.

7.1.3 Scope of Acceptance

A Quality System accepted by ABS will only apply to the particular plant that has been qualified, and does not extend to other plants under the control of the manufacturer; neither does it apply to licensees, subcontractors, nor suppliers. However, the manufacturer's system for controlling the quality of important purchased materials, components, and services will be evaluated.

7.1.4 Maintenance of Approval

The quality system of an approved manufacturer will be reviewed periodically. To this end, the manufacturer's facilities and records are to be open to the Surveyor at all reasonable times.

7.1.5 Notification Responsibility

A manufacturer is responsible for notifying ABS of changes in the quality system.

7.1.6 Withdrawal of Approval

ABS approval of the manufacturer's Quality System may be withdrawn at any time by the ABS Materials Department if such action is warranted.

7.3 Procedures for Obtaining Approval

7.3.1 Prior to Approval

Before approval of the quality system can be granted, qualification of the Manufacturer (see Subsection 1/5) must be obtained for all products, as required by the Guide.

7.3.2 Manufacturer Application

The manufacturer is to apply to the local ABS Office, or to ABS Materials Department, for approval of the quality system.

7.3.3 Details on Application

The application for certification is to include a detailed description of quality policies, procedures, and organization, and is to be forwarded to the ABS Materials Department, through the local ABS Office.

7.3.4 On-Site Audit

After review of the quality manual, ABS will carry out an on-site audit of the plant to verify the effectiveness of the quality system. On-site surveillance audits will be carried out annually or as specified by ABS.

7.5 Quality Assurance Certificate

A certificate will be issued to the qualified manufacturer. Certificates will be valid for five years.

7.5.1 Certification of Other Products

To obtain certification of products other than those originally approved or qualified, the manufacturer must obtain an extension of certification from ABS.

7.5.2 Suspension of Certification

If the Quality System or product is found to be deficient, certification of the manufacturer's Quality System may be suspended and the manufacturer so notified in writing.

7.5.3 Withdrawal of Certification

If the manufacturer fails to correct, within a reasonable time, conditions that led to a suspension, certification will be withdrawn.

7.5.4 Renewal

The validity of the approval is to be a maximum of five years, renewable subject to an audit and assessment of the result of satisfactory survey during the preceding period. The Surveyor's report confirming no process changes, along with mechanical property statistical data for various approved grades, is to be made available to the ABS Engineering/Materials Department for review and issuance of renewal letter/certificate.

Manufacturers who have not produced the approved grades and products during the period preceding the renewal may be required to carry out approval tests, unless the results of production of similar grades of products during the period are evaluated by ABS and found acceptable for renewal.

7.7 Test Data and Documentation

The required documentation in Subsection 4/15 is to be retained by the manufacturer for submission to ABS as required.

9 Approval of Steel Mills – Rolled Bar and Plate for Chain and Accessories

9.1 Bar and Plate Material for Chain and Accessories, Including Pins

Bar and plate materials intended for chain and accessories are to be manufactured only by works approved by ABS. The approval is limited to a nominated supplier of bar or plate material. If a chain or accessory manufacturer wishes to use material from a number of suppliers, separate approval tests must be carried out for each supplier.

The approval process is to be made in accordance with Appendix 4, "Procedure for the Approval of Rolled Hull Structural Steel Manufacturer", of the *ABS Rules for Materials and Welding (Part 2)*.

9.3 Approval Restrictions

Approval will be given only after successful testing of the completed chain or accessory. The approval for each grade will normally be limited up to the maximum diameter or thickness equal to that of the chain diameter tested, or accessory diameter/thickness tested.

The rolling reduction ratio for bar is to be recorded and is to be at least 5:1.

The rolling reduction ratio for plate is to be recorded and is to be at least 3:1.

The rolling reduction ratio used in production can be higher, but should not be lower than that qualified.

9.5 Chemical Composition

The steelmaker is to submit a specification of the chemical composition of the material, which must be approved by ABS and by the chain or accessory manufacturer. For Grade R4, R4S, and R5 chain and accessories, the steel should contain a minimum of 0.20% molybdenum.

9.7 Heat Treatment Sensitivity Study for Rolled Bars

A heat treatment sensitivity study simulating chain or accessory production conditions shall be applied in order to verify mechanical properties and establish limits for temperature and time combinations.

The effect of variations in heat treatment upon the tensile and Charpy properties is to be carried out on no fewer than 16 test conditions.

All test details and results are to be submitted to ABS.

9.9 Strain Aging, Temper Embrittlement, Hydrogen Embrittlement

The steel manufacturer is to provide evidence in the form of furnace reports and test data, that the manufacturing process produces material that is resistant to strain aging, temper embrittlement, and for R3S, R4, R4S, and R5, hydrogen embrittlement. All test details and results are to be submitted to ABS.

11 Accessory Manufacturer Approval

(Note: The term "Accessory Manufacturer" is the Manufacturer of Record)

11.1 Approval of Forges and Foundries – Accessories

Forges and foundries intending to supply finished or semi-finished accessories are to be approved by ABS. A description of manufacturing processes and process controls is to be submitted to ABS. The scope of approval is to be agreed with ABS. The approval is to be limited to a nominated supplier of forged or cast material. If an accessory manufacturer wishes to use material from a number of suppliers, a separate approval must be carried out for each supplier.

Accessory manufacturers are to have a documented and effective quality system that meets ABS requirements. The provision of such a quality system is required in addition to, and not in lieu of, the witnessing of tests by a Surveyor as specified in Sections 2 to 5 of this Guide.

11.3 Approval Restrictions

Approval will be given only after successful testing of the completed accessory. The approval will normally be limited to the type of accessory and the ABS designated grade of accessory up to the maximum diameter or thickness equal to that of the completed accessory used for qualification. Qualification of accessory pins to maximum diameters is also required. Accessories of complex geometries will be subject to special approval.

11.5 Forging Reduction Ratio

For forgings – The forging reduction ratio, used in the qualification tests, from cast ingot/slab to forged component is to be recorded. The forging reduction ratio used in production can be higher, but should not be lower than that qualified.

11.7 Chemical Composition

The forge or foundry is to submit a specification of the chemical composition of the forged or cast material, which must be approved by ABS. For Grade R4, R4S, and R5 chain, the steel should contain a minimum of 0.20% molybdenum.

11.9 Strain Aging, Temper Embrittlement, Hydrogen Embrittlement

Forges and foundries are to provide evidence in the form of furnace reports and test data, that the manufacturing process produces material that is resistant to strain ageing, temper embrittlement, and for R4S and R5 grades, hydrogen embrittlement. All test details and results are to be submitted to ABS.

11.11 Heat Treatment Sensitivity Study

A heat treatment sensitivity study simulating accessory production conditions shall be applied in order to verify mechanical properties and establish limits for temperature and time combinations. (Cooling after tempering shall be appropriate to avoid temper embrittlement).

The effect of variations in heat treatment upon the tensile and Charpy properties is to be carried out on no fewer than 16 test conditions.

All test details and results are to be submitted to ABS.

11.13 CTOD Tests (Crack Tip Opening Displacement Tests)

For initial approval, CTOD tests are to be carried out on the particular ABS mooring grade of material. Three CTOD tests are to be carried out in accordance with a recognized standard such as BS 7448 Parts 1 & 2. The CTOD test piece is to be a standard 2 × 1 single edge notched bend specimen taken from the quarter thickness location. The minimum test piece size shall be 50 × 25 mm for accessory diameters less than 120 mm, and 80 × 40 mm for diameters 120 mm and above. The tests are to be taken at minus 20°C.

11.15 Furnace Calibration

Calibration of furnaces shall be verified by measurement and recording of temperature (surface and internal), using a calibration test piece with dimensions equivalent to the maximum size of accessory manufactured. Thermocouples are to be placed both on the surface and in a drilled hole located to the mid-thickness position of the calibration block.

Evidence of furnace surveys and calibration is to be provided.

11.17 R4S and R5 Additional Requirements

For R4S and R5 accessories, prior to approval, the manufacturer is to have undertaken experimental tests or have relevant supporting data to develop the accessory material. The tests and data are to include:

- Fatigue tests, hot ductility tests (no internal flaws are to develop whilst bending in the accessory forming temperature range)
- Welding parameter research
- Heat treatment study
- Strain age resistance
- Temper embrittlement study
- Stress corrosion cracking (SCC) data
- Hydrogen embrittlement (HE) study, using slow strain test pieces in hydrated environments

Reports indicating the results of experimental tests are to be submitted.

11.19 Manufacturing Process Approval

Manufacturers are to submit for review and approval the sequence of operations from receiving inspection to shipment, including details of the following manufacturing processes:

- i) Steel melting, treating, and pouring – including temperatures, monitoring, and control (for foundries)
- ii) Steel reheating – including temperatures, monitoring, and control (for forges)
- iii) Forging – including upsetting, reduction, and total hot-working ratio (for forges)
- iv) Repair welding procedures
- v) Heat treatment procedures, practices, temperatures and limits, heating/cooling rates – furnace types, temperature control and recording, quenching bath and agitation
- vi) Proof and break loading-method, machine, measurement, and recording
- vii) Nondestructive examination procedure

11.21 Qualification Testing

Qualification testing is to include, as a minimum, the tests and examinations on the largest diameter product for each grade for which approval is requested. All proof tests, break tests, and mechanical tests (tension and impact) are to be witnessed by the Surveyor. In addition, hardness distribution and CTOD tests (1/11.13) are to be done but need not be witnessed by the Surveyor. All tests are to be performed on a product that has been subjected to the final heat treatment. Mechanical tests are to be taken from a proof loaded product. Other tests such as hot ductility (creasing), corrosion tests, fatigue tests, and stress corrosion cracking, provide useful information about the characteristics of the accessory and such supporting data is to be submitted.

11.21.1 Chemical Analyses

Both ladle and product analyses are to be provided, and are to include carbon, manganese, silicon, phosphorous, sulfur, and all other intentionally added elements. Restrictions on residual elements are also to be submitted.

11.21.2 Proof Load and Break Load Test

Accessories are to withstand the proof loads given in Section 3, Table 1, in accordance with 5/3.1 and 5/3.3.

11.21.3 Mechanical Tests

11.21.3(a) Accessories. Tension and Charpy tests are to be carried out in accordance with 2/5.9.1 or 2/7.9.1 to meet the requirements of Section 1, Table 1. Tests are to be taken at a location of at least one diameter or one times the thickness, from the end of the accessory or pin.

- i) *Tension Test (One accessory is to be tested, as a minimum).* One tension test is to be conducted, with a specimen removed from the heaviest section on the main load path through the accessory.
- ii) *Charpy V-Notch (CVN) Impact Test (One accessory is to be tested, as a minimum).* Two sets of CVN transition curves are to be produced from the accessory, one set of specimens removed from the heaviest section on the main load path through the accessory. The other set is to be taken from a critical area such as the crown of a shackle, or the head of an H link.

11.21.3(b) Pins. Tension and Charpy tests are to be carried out at the mid length of the pin, in accordance with 5/7.11 to meet the requirements of Section 1, Table 1.

- i) *Tension Test (One pin is to be tested, as a minimum).* One tension test from a pin is to be conducted, with specimens removed in accordance with Section 2, Figure 1.
- ii) *Charpy V-Notch (CVN) Impact Test (One pin is to be tested, as a minimum).* Two sets of CVN transition curves are to be produced from the pin, with specimens removed in accordance with Section 2, Figure 1.

11.21.4 Hardness Tests

Hardness distribution is to be determined across a diameter using Vickers or Rockwell indenters. A diagram showing the hardness distribution is to be submitted. Hardness tests are to be taken at a location of at least one diameter or one times the thickness, from the end of the accessory or pin.

11.21.5 Microexamination – Accessories and Pins

Microspecimens are to be taken showing the microstructure at the surface, at the two-thirds radius and at the mid-thickness. The microspecimens are to be etched with a suitable etchant and photographed at 100X and 500X magnifications. Austenitic and ferritic grain sizes are to be determined and reported. Austenitic grain size is to be number 6 or finer, in accordance with ASTM E112. Specimens are to be taken at a location of at least one diameter or one times the thickness, from the end of the accessory or pin.

11.21.6 Macroexamination – Accessories and Pins

Two macrospecimens are to be taken showing:

- An accessory or pin longitudinal section showing the metal flow (for forgings) in the direction of the main load path
- An accessory or pin section in a direction perpendicular to the main load path

Macrosections are to be etched.

The macrospecimens are to be photographed at 1X.

No cracks, laps or surface imperfections are permitted.

Specimens are to be taken at a location of at least one diameter or one times the thickness, from the end of the accessory or pin.

13 Approval of Quality Systems at Accessory Manufacturers

13.1 Quality Provision

Accessory manufacturers are to have a documented and effective quality system that meets ABS requirements. The provision of such a quality system is required in addition to, and not in lieu of, the witnessing of tests by a Surveyor as specified in Sections 2 to 5 of this Guide.

13.1.1 Quality System General

The manufacturer is to have a documented, effective quality system to ISO 9001 that addresses the following:

- Management structure
- Corporate policies regarding quality
- Internal auditing practices
- Calibration practices for tools, gauges, thermocouples, etc.
- Receiving, in process and pre-delivery, inspection practice
- Testing practices
- Procedures for handling discrepant material
- Marking
- Storage
- Record retention

13.1.2 Manual of Quality System

The manufacturer is to submit details of the quality system employed at the plant in the form of a manual. The effectiveness of the system is to be verified by the Surveyor.

13.1.3 Scope of Acceptance

A Quality System accepted by ABS will only apply to the particular plant that has been qualified, and does not extend to other plants under the control of the manufacturer; neither does it apply to licensees, subcontractors, nor suppliers. However, the manufacturer's system for controlling the quality of important purchased materials, components, and services will be evaluated.

13.1.4 Maintenance of Approval

The quality system of an approved manufacturer will be reviewed periodically. To this end, the manufacturer's facilities and records are to be open to the Surveyor at all reasonable times.

13.1.5 Notification Responsibility

A manufacturer is responsible for notifying ABS of changes in the quality system.

13.1.6 Withdrawal of Approval

ABS approval of the manufacturer's Quality System may be withdrawn at any time by the ABS Materials Department if such action is warranted.

13.3 Procedures for Obtaining Approval

13.3.1 Prior to Approval

Before approval of the quality system can be granted, qualification of Manufacturer (see Subsection 1/11 must be obtained for all products as required by the Guide.

13.3.2 Manufacturer Application

The manufacturer is to apply to the local ABS Office, or to ABS Materials Department, for approval of the quality system.

13.3.3 Details on Application

The application for certification is to include a detailed description of quality policies, procedures, and organization, and is to be forwarded to the ABS Materials Department, through the local ABS Office.

13.3.4 On-Site Audit

After review of the quality manual, ABS will carry out an on-site audit of the plant to verify the effectiveness of the quality system. On-site surveillance audits will be carried out annually or as specified by ABS.

13.5 Quality Assurance Certificate

A certificate will be issued to the qualified manufacturer. Certificates will be valid for five years.

13.5.1 Certification of Other Products

To obtain certification of products other than those originally approved or qualified, the manufacturer must obtain an extension of certification from ABS.

13.5.2 Suspension of Certification

If the Quality System or product is found to be deficient, certification of the manufacturer's Quality System may be suspended and the manufacturer so notified in writing.

13.5.3 Withdrawal of Certification

If the manufacturer fails to correct, within a reasonable time, conditions that led to a suspension, certification will be withdrawn.

13.5.4 Renewal

The validity of the approval is to be a maximum of five years, renewable subject to an audit and assessment of the result of satisfactory survey during the preceding period. The Surveyor's report confirming no process changes, along with mechanical property statistical data for various approved grades, is to be made available to the ABS Engineering/Materials Department for review and issuance of renewal letter/certificate.

Manufacturers who have not produced the approved grades and products during the period preceding the renewal may be required to carry out approval tests, unless the results of production of similar grades of products during the period are evaluated by ABS and found acceptable for renewal.

13.7 Test Data and Documentation

The required documentation in Subsection 5/15 is to be retained by the manufacturer for submission to ABS as required.

SECTION 2 Material Requirements for Chain and Accessories

1 Scope

These requirements apply to rolled steels, forgings, and castings used for the manufacture of offshore mooring chain and accessories.

Rolled steel plates produced in accordance with recognized or proprietary Standards may be used in accessories, such as tri-plates or H links. The acceptance of such Standards will be considered on a case-by-case basis.

3 Rolled Steel Bars

3.1 Steel Bar Manufacture

The steels are to be manufactured by basic oxygen, electric furnace, or such other process as may be specially approved. All steels are to be killed and fine grain treated. The austenitic grain size is to be 6 or finer, in accordance with ASTM E112.

3.1.1 R3, R3S, R4, R4S and R5 Bars

Steel for bars intended for R3, R3S, R4, R4S and R5 chain is to be vacuum degassed (or approved proven alternative).

3.1.2 R4S and R5 Bars – Additional Information

For R4S and R5 bars, the following information is to be supplied by the bar manufacturer to the mooring chain or accessory manufacturer and the results included in the chain/accessory documentation.

- i)* Each heat is to be examined for non-metallic inclusions. The level of micro inclusions is to be quantified and assessed, to verify inclusion levels are acceptable for the final product.
- ii)* A sample from each heat is to be macroetched according to ASTM E381 or equivalent, to verify there is no injurious segregation or porosity.
- iii)* Jominy hardenability data, according to ASTM A255, or equivalent, is to be supplied with each heat.

3.3 Chemical Composition

For acceptance tests, the chemical composition of ladle samples of each heat is to be determined by the steel maker and is to comply with the approved specification.

3.5 Mechanical Tests

3.5.1 Test Frequency

Bars of the same nominal diameter are to be presented for test in batches of 50 tons or fraction thereof from the same heat. Test specimens are to be taken from material heat treated in the same manner as intended for the finished chain. One tensile and three impact test specimens are to be taken from two different bars (preferably from first and last bars) of steel from each heat unless the material from a heat is less than 50 tons, in which case tests from one bar will be sufficient. If, however, material from one heat differs 9.5 mm (0.375 in.) or more in diameter, one set of tests is to be taken from the thinnest and thickest material rolled.

3.5.2 Hydrogen Embrittlement Test Frequency

Each heat of Grade R3S, R4, R4S, and R5 steel bars is to be tested for hydrogen embrittlement. In the case of continuous casting, test samples representing both the beginning and the end of the charge shall be taken. In the case of ingot casting, test samples representing two different ingots shall be taken.

3.5.2(a) Hydrogen Embrittlement Test Details. Two (2) tensile test specimens shall be taken from the central region of bar material which has been subjected to the heat treatment cycle intended to be used in production. The specimens shall preferably have a diameter of 20 mm, alternatively 14 mm. One specimen is to be tested within maximum 3 hours after machining. For a 14 mm diameter specimen, the time limit is 1.5 hours. (Alternatively, the specimen may be cooled to –60°C immediately after machining and kept at that temperature for a period of maximum 5 days). The other specimen is to be tested after baking at 250°C for 4 hours, alternatively 2 hours for 14 mm diameter specimen.

A slow strain rate $< 0.0003s^{-1}$ must be used during the entire test, until fracture occurs. (This means approximately 10 minutes for a 20 mm diameter specimen).

Tensile strength, elongation, and reduction of area are to be reported. The requirement for the test is:

$$Z_1/Z_2 \geq 0.85$$

where:

Z_1 = reduction of area without baking

Z_2 = reduction of area after baking

If the requirement $Z_1/Z_2 \geq 0.85$ is not met, the bar material may be subjected to a hydrogen degassing treatment after agreement with ABS. New tests shall be performed after degassing.

3.5.3 Tensile and Charpy Test Requirements and Location

For all grades, one tensile and three Charpy V-notch specimens are to be taken from each sample selected. The test specimens are to be taken at approximately one-third radius below the surface, as shown in Section 2, Figure 1 and prepared in accordance with 2-1-1/Figures 2 and 3 of the *ABS Rules for Materials and Welding (Part 2)* or an appropriate national Standard. The results of all tests are to be in accordance with the appropriate requirements of Section 1, Table 1.

3.5.4 Retest Requirements for Tensile and Charpy Impact Tests

3.5.4(a) Tensile Retest. When a specimen fails to meet the tensile requirements of Section 1, Table 1, retests may be permitted. Two additional tests are to be performed; each individual value obtained from the tests is to comply with the requirements of Section 1, Table 1. If either or both additional tests fail to meet the specified requirements, the material from that batch is to be rejected unless the failure is clearly attributable to improper simulated heat treatment

3.5.4(b) Charpy Retest. When the average value of the three initial Charpy V-notch impact specimens fails to meet the stated requirement, or the value for more than one specimen is below the required average value, or when the value for any one specimen is below 70% of the specified average value, three additional specimens from the same material may be tested and the results added to those previously obtained to form a new average. If this new average complies with the requirements and if no more than two individual results are lower than the required average and no more than one result is below 70% of the specified average value, the lot (i.e., material of one diameter from the same heat and heat-treated at the same time) may be accepted. If the new average does not comply with the requirements, the material from that batch is to be rejected unless the failure is clearly attributable to improper simulated heat treatment.

3.5.5 Rejection

Failure to meet the retest requirements will result in rejection of the batch represented unless it can be clearly attributable to improper simulated heat treatment.

FIGURE 1
Sampling for Tension Specimens and Charpy V-Notch Specimens
Steel Bars, Forgings and Castings

For non-circular sections, $1/4t$ (thickness) from the surface is considered appropriate.

Plates are to be tested to the Standard to which they are produced.

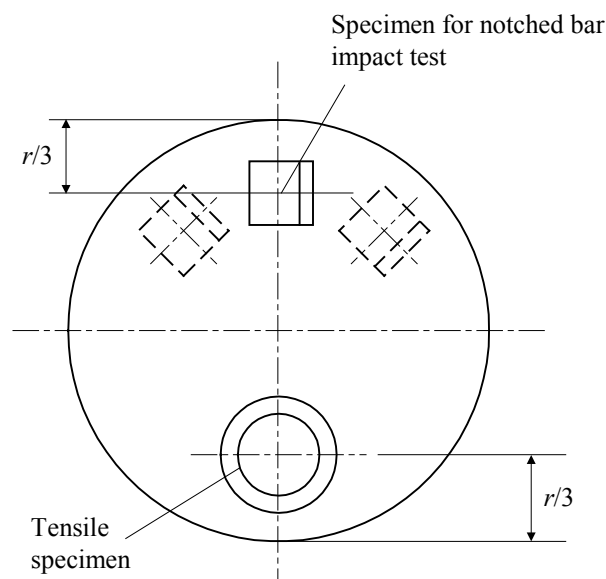

3.7 Dimensional Tolerances

The diameter and roundness shall be within the tolerances specified in Section 2, Table 1, unless otherwise agreed.

TABLE 1
Dimensional Tolerance of Bar Stock

<i>Nominal Diameter in millimeters (inches)</i>	<i>Tolerance on Diameter in millimeters (inches)</i>	<i>Tolerance on Roundness d_{max} measured – d_{min} measured in millimeters (inches)</i>
less than 25 (less than 1.0)	-0 + 1.0 (-0 + 0.04)	0.6 (0.024)
25 to 35 (1.0 to 1.4)	-0 + 1.2 (-0 + 0.048)	0.8 (0.032)
36 to 50 (1.5 to 1.9)	-0 + 1.6 (-0 + 0.064)	1.1 (0.044)
51 to 80 (2.0 to 3.1)	-0 + 2.0 (-0 + 0.079)	1.50 (0.059)
81 to 100 (3.2 to 4.0)	-0 + 2.6 (-0 + 0.10)	1.95 (0.077)
101 to 120 (4.1 to 4.7)	-0 + 3.0 (-0 + 0.12)	2.25 (0.089)
121 to 160 (4.8 to 6.3)	-0 + 4.0 (-0 + 0.16)	3.00 (0.12)
161 – 210 (6.4 – 8.3)	-0 + 5.0 (-0 + 0.197)	4.00 (0.16)

3.9 Nondestructive Examination and Repair

NDE is to be performed in accordance with recognized Standards, and the NDE procedures, together with rejection/acceptance criteria, are to be submitted to ABS. Operators are to be appropriately qualified (to a minimum level II in accordance with a recognized Standard such as ISO 9712, SNT-TC-1A, EN 473 or ASNT Central Certification Program) in the method of nondestructive examination.

3.9.1 Volumetric Inspection – UT

The bars shall be free of pipe, cracks, and flakes. One hundred percent of bar material intended for chains, accessories, and pins is to be subjected to ultrasonic examination at an appropriate stage of the manufacture.

3.9.2 Surface Inspection – MPI and EC

One hundred percent of the bar material is to be examined by magnetic particle or eddy current methods. The bars shall be free of injurious surface imperfections such as seams, laps, and rolled-in mill scale. Provided that their depth is not greater than 1% of the bar diameter, longitudinal discontinuities may be removed by grinding and blending to a smooth contour.

3.9.3 Frequency

The frequency of NDE may be reduced at the discretion of ABS, provided it is verified by statistical means that the required quality is consistently achieved.

3.11 Marking

Each bar is to be stamped with the steel grade designation and the charge number (or a code indicating the charge number) on one of the end surfaces. Other marking methods may be accepted subject to agreement.

3.13 Heat Treatment of Rolled Bars Intended for Accessory Pins

Rolled steel bars intended for accessory pins are to be properly heat treated in compliance with specifications submitted and approved.

- Bars in furnaces are to be positioned so that the heat transfer between furnace and bars is not influenced by other bars.
- Bars are not to be stacked on top of each other in the furnaces.
- Positions of bars in furnaces are to be recorded.
- During quenching, bars are to be positioned so that the heat transfer between quenching medium and the bar is not influenced by other bars.
- During accelerated cooling after tempering, bars are to be positioned so that the heat transfer between quenching medium and the bar is not influenced by other bars.

5 Forged Steel

5.1 Forged Steel Accessories

Forged steels used for the manufacture of accessories must be in compliance with approved specifications and the submitted test reports approved by the ABS Surveyor. The steels are to be manufactured by basic oxygen, electric furnace, or such other process as may be specially approved. All steels are to be killed and fine grain treated. The austenitic grain size is to be 6 or finer in accordance with ASTM E112.

5.1.1 R3, R3S, R4, R4S, and R5 Forgings

Steel for forgings intended for R3, R3S, R4, R4S, and R5 chain is to be vacuum degassed (or approved proven alternative).

5.1.2 R4S and R5 Additional Requirements

For steel intended for R4S and R5 accessories, the following information is to be supplied by the steel manufacturer to the mooring accessory manufacturer and the results included in the accessory documentation.

- i) Each heat is to be examined for non-metallic inclusions. The level of micro inclusions is to be quantified and assessed, to verify inclusion levels are acceptable for the final product.
- ii) A sample from each heat is to be macroetched according to ASTM E381 or equivalent, to verify there is no injurious segregation or porosity.
- iii) Jominy hardenability data, according to ASTM A255, or equivalent, is to be supplied with each heat.

5.3 Chemical Composition

For acceptance tests, the chemical composition of ladle samples of each heat is to be determined by the steel maker and is to comply with the approved specification.

5.5 Heat Treatment

Finished forgings are to be properly heat treated in compliance with specifications submitted and approved.

- Forgings in furnaces are to be positioned so that the heat transfer between furnace and forgings is not influenced by other forgings.
- Forgings are not to be stacked on top of each other in the furnaces.
- Positions of forgings in furnaces are to be recorded.
- During quenching, forgings are to be positioned so that the heat transfer between quenching medium and the forging is not influenced by other forgings.
- During accelerated cooling after tempering, forgings are to be positioned so that the heat transfer between quenching medium and the forging is not influenced by other forgings.

5.7 Mechanical Properties

The forgings must comply with the mechanical properties given in Section 1, Table 1, when properly heat treated.

5.9 Mechanical Tests

5.9.1 Tensile and Charpy Test Frequency and Location

For test sampling, forgings of similar dimensions (diameters do not differ by more than 25 mm) originating from the same heat treatment charge and the same heat of steel are to be combined into one test unit. From each test unit, one tensile and three impact test specimens are to be taken and tested and prepared in accordance with 2-1-1/Figures 2 and 3 of the *ABS Rules for Materials and Welding (Part 2)* or an appropriate national Standard. The test specimens are to be taken at approximately one-third radius below the surface, as shown in Section 2, Figure 1.

5.9.2 Retest Requirements for Tensile and Charpy Impact Tests

5.9.2(a) Tensile Retest. When a specimen fails to meet the tensile requirements of Section 1, Table 1, retests may be permitted. Two additional tests are to be performed; each individual value obtained from the tests is to comply with the requirements of Section 1, Table 1. If either or both additional tests fail to meet the specified requirements, the material from that batch is to be rejected unless the failure is clearly attributable to improper simulated heat treatment

5.9.2(b) Charpy Retest. When the average value of the three initial Charpy V-notch impact specimens fails to meet the stated requirement, or the value for more than one specimen is below the required average value, or when the value for any one specimen is below 70% of the specified average value, three additional specimens from the same material may be tested and the results added to those previously obtained to form a new average. If this new average complies with the

requirements and if no more than two individual results are lower than the required average and no more than one result is below 70% of the specified average value, the lot (i.e., material of one diameter from the same heat and heat-treated at the same time) may be accepted. If the new average does not comply with the requirements, the material from that batch is to be rejected unless the failure is clearly attributable to improper simulated heat treatment.

5.9.2(c) *Rejection.* Failure to meet the retest requirements will result in rejection of the batch represented unless it can be clearly attributable to improper simulated heat treatment.

5.11 Nondestructive Examination

NDE is to be performed in accordance with recognized Standards and the NDE procedures, together with rejection/acceptance criteria are to be submitted to ABS. Operators are to be appropriately qualified (to a minimum level II in accordance with a recognized Standard such as ISO 9712, SNT-TC-1A, EN 473 or ASNT Central Certification Program) in the method of nondestructive examination.

5.11.1 Extent of UT

The forgings are to be subjected to one hundred percent ultrasonic examination at an appropriate stage of manufacture and in compliance with the standard submitted and approved.

5.11.2 Surface Inspection

Forgings shall be free of injurious surface imperfections such as seams, forging laps, and scale.

5.13 Marking

Each forging is to be stamped with the steel grade designation and the charge number (or a code indicating the charge number) on one of the end surfaces. Other marking methods may be accepted subject to agreement.

7 Cast Steel

7.1 Cast Steel Accessories

Cast steels used for the manufacture of accessories must be in compliance with approved specifications and the submitted test reports approved by the ABS Surveyor. The steels are to be manufactured by basic oxygen, electric furnace or such other process as may be specially approved. All steels are to be killed and fine grain treated. The austenitic grain size is to be 6 or finer in accordance with ASTM E112.

7.1.1 R3, R3S, R4, R4S, and R5 Castings

Steel for castings intended for R3, R3S, R4, R4S, and R5 accessories is to be vacuum degassed (or approved proven alternative).

7.1.2 R4S and R5 Additional Requirements

For steel intended for R4S and R5 accessories the following information is to be obtained and the results included in the accessory documentation.

- i)* Each heat is to be examined for non-metallic inclusions. The level of micro inclusions is to be quantified and assessed, to verify inclusion levels are acceptable for the final product.
- ii)* A sample from each heat is to be macroetched according to ASTM E381 or equivalent, to verify there is no injurious segregation or porosity.
- iii)* Jominy hardenability data, according to ASTM A255, or equivalent, is to be supplied with each heat.

7.3 Chemical Composition

For acceptance tests, the chemical composition of ladle samples of each heat is to be determined by the steel maker and is to comply with the approved specification.

7.5 Heat Treatment

All castings are to be properly heat treated in compliance with specifications submitted and approved.

- Castings in furnaces are to be positioned so that the heat transfer between furnace and castings is not influenced by other castings.
- Castings are not to be stacked on top of each other in the furnaces.
- Positions of castings in furnaces are to be recorded.
- During quenching castings are to be positioned so that the heat transfer between quenching medium and the casting is not influenced by other castings.
- During accelerated cooling after tempering castings are to be positioned so that the heat transfer between quenching medium and the casting is not influenced by other castings.

7.7 Mechanical Properties

The castings must comply with the mechanical properties given in Section 1, Table 1, when properly heat treated.

7.9 Mechanical Tests

7.9.1 Tensile and Charpy Test Frequency and Location

For test sampling, castings of similar dimensions originating from the same heat treatment charge and the same heat of steel are to be combined into one test unit. From each test unit, one tensile and three impact test specimens are to be taken and tested and prepared in accordance with 2-1-1/Figures 2 and 3 of the *ABS Rules for Materials and Welding (Part 2)* or an appropriate national Standard. The test specimens are to be taken at approximately one-third radius below the surface, as shown in Section 2, Figure 1.

7.9.2 Retest Requirements for Tensile and Charpy Impact Tests

7.9.2(a) Tensile Retest. When a specimen fails to meet the tensile requirements of Section 1, Table 1, retests may be permitted. Two additional tests are to be performed; each individual value obtained from the tests is to comply with the requirements of Section 1, Table 1. If either or both additional tests fail to meet the specified requirements, the material from that batch is to be rejected unless the failure is clearly attributable to improper simulated heat treatment.

7.9.2(b) Charpy Retest. When the average value of the three initial Charpy V-notch impact specimens fails to meet the stated requirement, or the value for more than one specimen is below the required average value, or when the value for any one specimen is below 70% of the specified average value, three additional specimens from the same material may be tested and the results added to those previously obtained to form a new average. If this new average complies with the requirements and if no more than two individual results are lower than the required average and no more than one result is below 70% of the specified average value, the lot (i.e., material of one diameter from the same heat and heat-treated at the same time) may be accepted. If the new average does not comply with the requirements, the material from that batch is to be rejected unless the failure is clearly attributable to improper simulated heat treatment.

7.9.2(c) Rejection. Failure to meet the retest requirements will result in rejection of the batch represented unless it can be clearly attributable to improper simulated heat treatment. For the location of the test specimens see Section 2, Figure 1.

7.11 Nondestructive Examination

NDE is to be performed in accordance with recognized Standards and the NDE procedures, together with rejection/acceptance criteria are to be submitted to ABS. Operators are to be appropriately qualified (to a minimum level II in accordance with a recognized Standard such as ISO 9712, SNT-TC-1A, EN 473 or ASNT Central Certification Program) in the method of nondestructive examination.

7.11.1 Extent of Ultrasonic Examination

The castings are to be subjected to one hundred percent ultrasonic examination in compliance with the standard submitted and approved.

7.11.2 Surface Inspection of Castings

Castings shall be free of injurious surface imperfections.

7.13 Marking

Each casting is to be stamped with the steel grade designation and the charge number (or a code indicating the charge number) on one of the end surfaces. Other marking methods may be accepted subject to agreement.

9 Materials for Studs

Studs intended for stud link chain cable are to be made of steel corresponding to that of the chain or in compliance with specifications submitted and approved. In general, the carbon content should not exceed 0.25% if the studs are to be welded in place.

SECTION **3** **Design and Manufacture of Chain and Accessories**

1 Design

1.1 Design Details

Drawings, giving detailed design of chain and accessories are to be submitted for approval. Standard designs are given in ISO 1704. ISO 1704 includes details of application of enlarged links, end links and shackles.

Chain common link geometry and proportions are to comply with the requirements of this Guide. Other proportions are to be specially approved.

It should be considered that new or non-standard designs of chain or accessories will require the submittal to ABS of a detailed stress analysis, a fatigue analysis, and possible performance, fatigue, or corrosion fatigue testing.

1.3 Stud Link Chain

For stud link chain, drawings showing the detailed design of the stud shall be submitted for information. The stud shall give an impression in the chain link which is sufficiently deep to secure the position of the stud, but the combined effect of shape and depth of the impression shall not cause any harmful notch effect or stress concentration in the chain link.

Studs are to be securely fastened by press fitting. Where plastic straining is used to set studs, the applied load is not to be greater than that qualified in 1/5.11

1.5 Kenter Shackles

Machining of Kenter shackles shall result in a fillet radius minimum 3% of nominal diameter.

1.7 Special Subsea Mooring Connectors

Drawings and detailed analysis are to be submitted in order to qualify the design. Consideration such as compatibility with chain links or accessories needs to be given with respect to loading, fitting, corrosion, and wear.

1.9 Ancillary Accessory Components

The design details of ancillary components to accessories, such as bushes, thimbles, and bearings are to be submitted.

3 Chain Cable Manufacturing Process

Offshore mooring chain shall be manufactured in continuous lengths by flash butt welding and is to be heat treated in a continuous furnace; batch heat treatment is not permitted.

3.1 Joining Shackles and Splice Links

The use of joining shackles to replace defective links is subject to the written approval of the end purchaser in terms of the number and type permitted. The use of connecting common links (splice links) is restricted to three (3) links in each 100 m of chain.

5 Chain Cable Manufacturing Process Records

Records of bar heating, flash welding, and heat treatment shall be made available for inspection by the Surveyor.

5.1 Bar Heating

For electric resistance heating, the heating phase shall be controlled by an optical heat sensor. The controller shall be checked at least once every 8 hours and records made.

For furnace heating, the heat shall be controlled and the temperature continuously recorded using thermocouples in close proximity to the bars. The controls shall be checked at least once every 8 hours and records made.

5.3 Flash Welding of Chain Cable

The following welding parameters shall be controlled during welding of each link:

- i)* Platen motion
- ii)* Current as a function of time
- iii)* Hydraulic pressure

The controls shall be checked at least every 4 hours and records made.

5.5 Heat Treatment of Chain Cable

Chain shall be austenitized, at a combination of temperature and time within the limits established during initial qualification.

When applicable, chain shall be tempered at a combination of temperature and time within the limits established during initial qualification.

Cooling after tempering shall be appropriate to avoid temper embrittlement.

Temperature and time, or temperature and chain speed shall be controlled and continuously recorded.

7 Mechanical Properties

The mechanical properties of finished chain are to be in accordance with Section 1, Table 1. For the location of test specimens see Section 2, Figure 1 and Section 3, Figure 1.

9 Proof and Breaking Test Loads

Chains are to withstand the proof and break test loads given in Section 3, Table 1.

11 Freedom from Defects

All chains are to have a workmanlike finish consistent with the method of manufacture and be free from defects. Each link is to be examined in accordance with Subsection 4/9 using approved procedures.

FIGURE 1
Test Sample Locations in Link

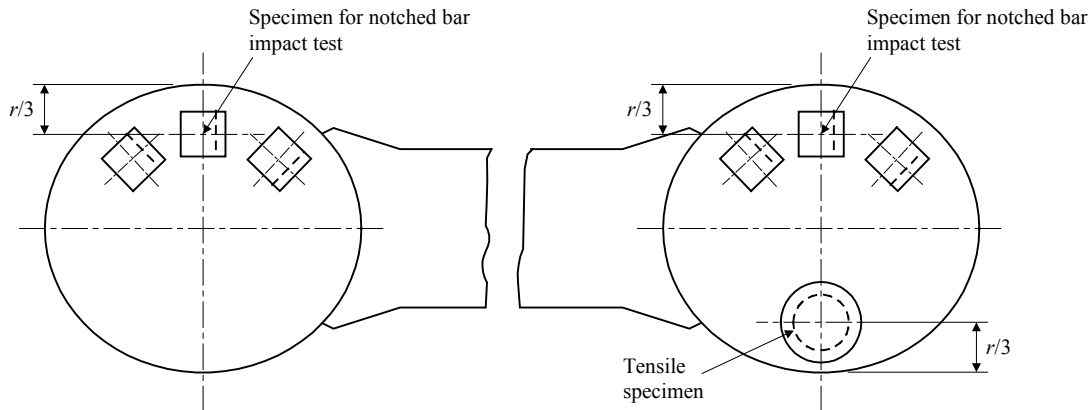

TABLE 1
Formulas for Proof and Break Test Loads, Weight, and 5-Link Length

Test Load, in kN [lb]	Grade R3 Stud Link	Grade R3S Stud Link	Grade R4 Stud Link	Grade R4S Stud Link	Grade R5 Stud Link
Proof	$0.0156d^2(44 - 0.08d)$ [2262d ² (44 - 2.032d)]	$0.0180d^2(44 - 0.08d)$ [2610d ² (44 - 2.032d)]	$0.0216 d^2(44 - 0.08d)$ [3125d ² (44 - 2.032d)]	$0.0240 d^2(44 - 0.08d)$ [3482d ² (44 - 2.032d)]	$0.0251d^2(44 - 0.08d)$ [3642d ² (44 - 2.032d)]
Break	$0.0223d^2(44 - 0.08d)$ [3236d ² (44 - 2.032d)]	$0.0249d^2(44 - 0.08d)$ [3610d ² (44 - 2.032d)]	$0.0274d^2(44 - 0.08d)$ [3977d ² (44 - 2.032d)]	$0.0304d^2(44 - 0.08d)$ [4411d ² (44 - 2.032d)]	$0.0320d^2(44 - 0.08d)$ [4643d ² (44 - 2.032d)]
Test Load, in kN [lb]	Grade R3 Studless	Grade R3S Studless	Grade R4 Studless	Grade R4S Studless	Grade R5 Studless
Proof	$0.0156d^2(44 - 0.08d)$ [2262d ² (44 - 2.032d)]	$0.0174d^2(44 - 0.08d)$ [2527d ² (44 - 2.032d)]	$0.0192d^2(44 - 0.08d)$ [2784d ² (44 - 2.032d)]	$0.0213d^2(44 - 0.08d)$ [3091d ² (44 - 2.032d)]	$0.0223d^2(44 - 0.08d)$ [3236d ² (44 - 2.032d)]
Break	$0.0223d^2(44 - 0.08d)$ [3236d ² (44 - 2.032d)]	$0.0249d^2(44 - 0.08d)$ [3610d ² (44 - 2.032d)]	$0.0274d^2(44 - 0.08d)$ [3977d ² (44 - 2.032d)]	$0.0304d^2(44 - 0.08d)$ [4411d ² (44 - 2.032d)]	$0.0320d^2(44 - 0.08d)$ [4643d ² (44 - 2.032d)]
Chain Weight, in kg/m [lb/ft]	Stud link = $0.0219d^2$ (9.50d ²)				
Chain Weight, in kg/m [lb/ft]	Studless chain and non standard links Weight calculations for each design are to be submitted.				
Pitch Length	5-Link Measure				
Minimum	5-Link measurement 22d (excludes non-standard links)				
Maximum	5-Link measurement 22.55d (excludes non-standard links)				

d = nominal diameter of chain

13 Dimensions and Dimensional Tolerances

13.1 Link Shape and Proportion

The shape and proportion of links is to conform to ISO 1704 or the designs specially approved.

13.3 Tolerances Applicable to Chain Links

The following tolerances are applicable to chain links:

i) *Diameter Tolerances of Finished Chain*

Chain Diameter, in millimeters (inches)		Plus Tolerance ⁽¹⁾	Minus Tolerance ⁽²⁾ at Crown in millimeters (inches)	Minus Tolerance ⁽³⁾ Elsewhere
Over	up to			
-----	40 (1 ⁹ / ₁₆)	0.05d	1 (1/ ₃₂)	0
40 (1 ⁹ / ₁₆)	84 (3 ³ / ₈)	0.05d	2 (1/ ₁₆)	0
84 (3 ³ / ₈)	122 (4 ⁷ / ₈)	0.05d	3 (1/ ₈)	0
122 (4 ⁷ / ₈)	152 (6)	0.05d	4 (5/ ₃₂)	0
152 (6)	184 (7 ¹ / ₄)	0.05d	6 (1/ ₄)	0
184 (7 ¹ / ₄)	210 (8 ¹ / ₄)	0.05d	7.5 (1 ⁹ / ₆₄)	0

Notes:

- 1 The flash weld region diameter plus tolerances are to be specially considered during manufacturer approval.
- 2 Minus tolerance in the plane of the link at the crown is permitted to the extent shown above provided the cross-sectional area of the link at that point is at least the theoretical area of the nominal diameter.
- 3 For allowable diameter reduction due to grinding repair, see 4/11.5.

d = nominal diameter of chain

- ii) The allowable manufacturing tolerance on a length of five links is +2.5%, but may not be negative.
- iii) The tolerances for stud link and studless common links are to be measured in accordance with Section 3, Figure 2.
- iv) For stud link chain, studs must be located in the links centrally and at right angles to the sides of the link. The following tolerances in Section 3, Figure 2 are acceptable provided that the stud fits snugly and its ends lie flush against the inside of the link:

FIGURE 2A
Proportions, Dimensions and Tolerances of Stud Link Common Link

The internal link radii (R) and external radii should be uniform.

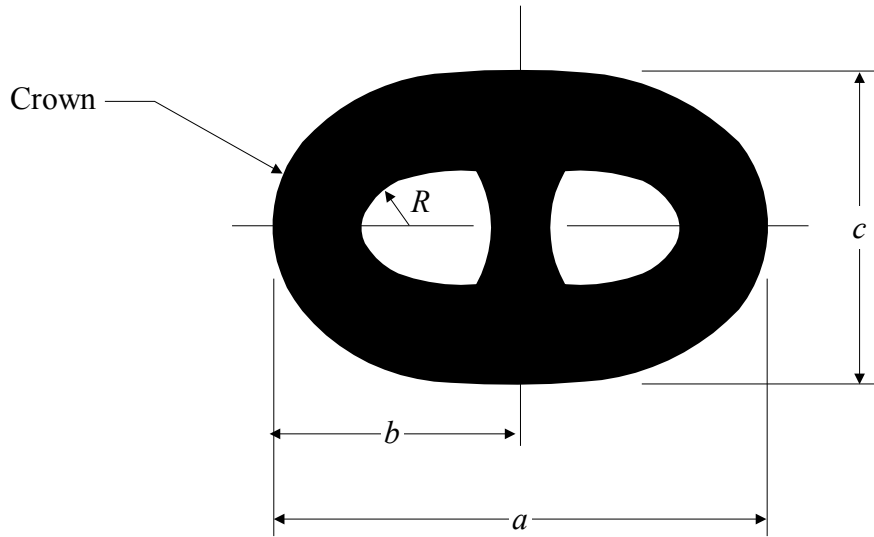

<i>Designation ⁽¹⁾</i>	<i>Description</i>	<i>Nominal Dimension of the Link</i>	<i>Minus Tolerance</i>	<i>Plus Tolerance</i>
<i>a</i>	Link Length	$6d$	$0.15d$	$0.15d$
<i>b</i>	Link Half Length	$a^*/2$	$0.1d$	$0.1d$
<i>c</i>	Link Width	$3.6d$	$0.09d$	$0.09d$
<i>e</i>	Stud Angular Misalignment	0 degrees	4 degrees	4 degrees
<i>R</i>	Inner Radius	$0.65d$	0	-----

Notes:

1 Dimension designation is shown in above figure.

d = nominal diameter of chain

a^* = actual link length

FIGURE 2B
Proportions, Dimensions and Tolerances of Studless Common Link

The internal link radii (R) and external radii should be uniform.

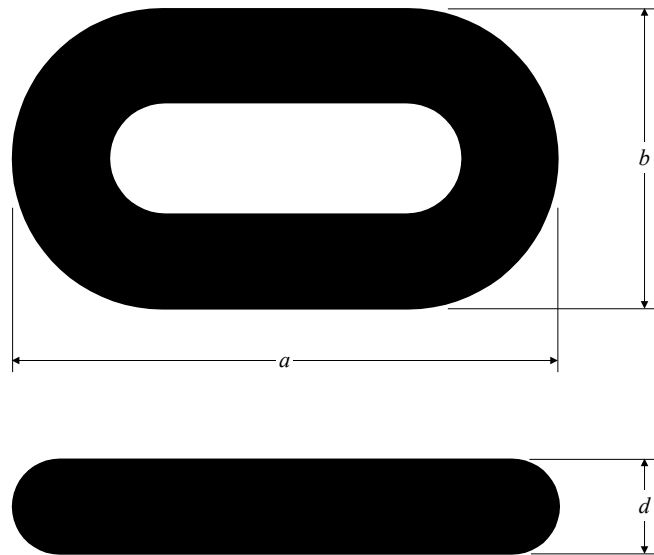

Designation ⁽¹⁾	Description	Nominal Dimension of the Link	Minus Tolerance	Plus Tolerance
<i>a</i>	Link Length	$6d$	$0.15d$	$0.15d$
<i>b</i>	Link Width	$3.35d$	$0.09d$	$0.09d$
<i>R</i>	Inner Radius	$0.65d$	0	-----

Notes:

- 1 Dimension designation is shown in above figure.
 d = nominal diameter of chain
- 2 Other dimension ratios are subject to special approval.

15 Stud Link Chain – Welding of Studs

A welded stud may be accepted for grade R3 and R3S chains. Welding of studs in grades R4, R4S, and R5 chain is not permitted unless specially approved.

15.1 Heat Treatment of Welded Studs

Where studs are welded into the links this is to be completed before the chain is heat treated.

15.3 Extent of Stud Weld

The stud ends must be a good fit inside the link and the weld is to be confined to the stud end opposite to the flash butt weld. The full periphery of the stud end is to be welded unless otherwise approved.

15.5 Single Weld

Welding of studs both ends is not permitted unless specially approved.

15.7 Weld Procedure – Studs

The welds are to be made by qualified welders using an approved procedure and low-hydrogen approved consumables.

15.9 Fillet Size

The size of the fillet weld shall as a minimum be as per API Specification 2F.

15.11 Weld Quality

The welds are to be of good quality and free from defects such as cracks, lack of fusion, gross porosity, and undercuts exceeding 1 mm ($1/32$ in.).

15.13 Stud Weld Inspection

All stud welds shall be visually examined. 50% of all stud welds within each length of chain shall be examined by dye penetrant or magnetic particles after proof testing. If cracks or lack of fusion are found, all stud welds in that length are to be examined.

17 Connecting Common Links (Splice Links)

17.1 Procedure Approval

Single links to substitute for test links or defective links without the necessity for re-heat treatment of the whole length are to be made in accordance with an approved procedure. Separate approvals are required for each grade of chain and the tests are to be made on the maximum size of chain for which approval is sought.

17.3 Adjacent Links to Splice Links

Manufacture and heat treatment of connecting common link is not to affect the properties of the adjoining links. The temperature reached by these links is nowhere to exceed 250°C.

17.5 Testing and Inspection

Each link is to be subjected to the appropriate proof load and nondestructive examination as detailed in Section 3, Table 1 and Subsection 4/9. A second link shall be made identical to the connecting common link, and the link shall be tested and inspected per Subsections 4/3, 4/7, and 4/9. Mechanical tests are to be done after proof loading as per 4/7.1.

Note the break test in 4/3.1 need only be done on 50% of the test specimen splice links produced. This means that the mechanical tests will be taken from a break loaded link on every second specimen link. If only one splice link is required, two additional identical specimen links shall be made, one for mechanical tests and one for the break test. If it has been previously demonstrated that the break test does not influence the mechanical properties of a particular material, then only one additional identical specimen link need be produced, and both the break test and mechanical test can be completed on the same sample link.

17.7 Identification

Each connecting common link is to be marked:

- On the stud for stud link chain,
- On the outer straight length on the side opposite the flash butt weld for studless chain,

in accordance with Subsection 4/13 plus a unique number for the link.

The adjoining links are also to be marked on the studs or straight length as above.



SECTION 4 Testing and Inspection of Finished Chain

1 General

After final heat treatment, all chain is to be subjected to proof load tests, sample break load tests, and sample mechanical tests in the presence of a Surveyor. Where the manufacturer has a procedure to record proof loads and the Surveyor is satisfied with the adequacy of the recording system, he need not witness all proof load tests. The Surveyor is to satisfy himself that the testing machines are calibrated and maintained in a satisfactory condition. Prior to testing and inspection, the chain is to be free from scale, paint, or other coating. The chain shall be sand or shot blasted to meet this requirement.

3 Proof and Break Load Tests

3.1 Proof Load Test

The entire length of chain shall withstand the proof load specified in Section 3, Table 1 without fracture and shall not crack in the flash weld. The load applied shall not exceed the proof load by more than 10% when stretching the chain. The proof load is to be applied twice with 180 degrees axial rotation between the two load applications, unless the chain is tested vertically or horizontal supports are provided to give a uniform stress distribution in the test length.

Where plastic straining is used to set studs, the applied load is not to be greater than that qualified in approval tests in 1/5.11.

3.3 Break Test Specimens

A break-test specimen consisting of at least three (3) links is to be either taken from the chain or produced at the same time and in the same manner as the chain. The test frequency is to be based on tests at sampling intervals according to Section 4, Table 1, provided that every cast is represented. Each specimen shall be capable of withstanding the break load specified without fracture and shall not crack in the flash weld. It shall be considered acceptable if the specimen is loaded to the specified value and maintained at that load for 30 seconds.

3.3.1 Alternative Break Test

For chain diameters over 100 mm (4 in.), alternative break-test proposals to the above break-test will be considered whereby a one link specimen is used. Alternatives are to be approved by ABS, each heat is to be represented, the test frequency is to be in accordance with Section 4, Table 1, and it is to be demonstrated and proven that the alternative test represents an equivalent load application to the three link test.

3.3.2 Break Test Capacity

If the loading capacity of the testing machine is insufficient, another equivalent method shall be agreed with ABS.

TABLE 1
Frequency of Break and Mechanical Tests

<i>Nominal Chain Diameter, in millimeters (inches)</i>		<i>Maximum Sampling Interval, in meters (feet)</i>
<i>Over</i>	<i>Up to</i>	
-----	48 (1 ⁷ / ₈)	91 (300)
48 (1 ⁷ / ₈)	60 (2 ³ / ₈)	110 (360)
60 (2 ³ / ₈)	73 (2 ⁷ / ₈)	131 (430)
73 (2 ⁷ / ₈)	85 (3 ³ / ₈)	152 (500)
85 (3 ³ / ₈)	98 (3 ⁷ / ₈)	175 (575)
98 (3 ⁷ / ₈)	111 (4 ³ / ₈)	198 (650)
111 (4 ³ / ₈)	124 (4 ⁷ / ₈)	222 (730)
124 (4 ⁷ / ₈)	137 (5 ³ / ₈)	250 (820)
137 (5 ³ / ₈)	149 (5 ⁷ / ₈)	274 (900)
149 (5 ⁷ / ₈)	162 (6 ³ / ₈)	297 (975)
162 (6 ³ / ₈)	175 (6 ⁷ / ₈)	322 (1056)
176 (6 ⁷ / ₈)	186 (7 ³ / ₈)	346 (1135)
187 (7 ³ / ₈)	199 (7 ⁷ / ₈)	370 (1214)
199 (7 ⁷ / ₈)	212 (8 ³ / ₈)	395 (1296)

5 Dimensions and Dimensional Tolerances

5.1 Individual Link Measurement – After Proof Load

After proof load testing, measurements are to be taken on at least 5% of the links in accordance with Subsection 3/13.

5.3 Five-Link Measurement – After Proof Load

The entire chain is to be checked for the length, five links at a time. By the five-link check, the first five links shall be measured. From the next set of five links, at least two links from the previous five links set shall be included. This procedure is to be followed for the entire chain length. The measurements are to be taken preferably while the chain is loaded to 5-10% of the minimum proof load. The links held in the end blocks may be excluded from this measurement.

If the length of the proof loaded chain over five links is short, the chain may be stretched in accordance with 4/11.1.

7 Mechanical Tests on Completed Chain – After Proof Load

7.1 Specified Tests

Links of samples detached from finished, heat treated, and proof loaded chain shall be sectioned for determination of mechanical properties. A test unit shall consist of two tensile and nine impact specimens from the following locations:

- One tensile clear of the weld
- One tensile with the weld in the center of the specimen (not required for R3)
- Three CVN specimens clear of the weld (opposite side to flash weld)
- Three CVN specimens with notch in weld seam
- Three CVN specimens from the crown

Where the strain-aging properties of the steel have been documented by sufficient testing and comparative testing demonstrates that values obtained from heat treated, proof loaded chain are not significantly inferior to those from heat treated, non-proof loaded chain, the mechanical tests may be carried out on heat treated chain links that are not subjected to the proof load. Acceptance criteria for heat treated, non-proof loaded chain is to be agreed.

7.3 Test Frequency and Properties

The test frequency is to be based on tests at sampling intervals according to Section 4, Table 1, provided that every cast is represented. Mechanical properties shall be as specified in Section 1, Table 1.

7.5 Frequency of Crown Impact Tests

The frequency of impact testing in the bend may be reduced at the discretion of ABS, provided it is verified by statistical means that the required toughness is consistently achieved.

9 Nondestructive Examination – After Proof Load Test

9.1 Visual Inspection

After proof testing and cleaning, all surfaces of every link shall be visually examined by the manufacturer for workmanship, circularity, distortion, stud attachment, test grip damage, surface appearance, alignment of butt welds (eccentricity), and clamping die damage. Burrs, irregularities, and rough edges shall be contour ground. Links shall be uniform and have smooth internal radii, and are to be free from injurious surface imperfections such as mill defects, surface cracks, dents, and cuts, especially in the vicinity where gripped by clamping dies during flash welding. Studs shall be securely fastened. The examination room/area should be appropriately illuminated and the chain should be positioned to have good access to all surfaces.

9.3 Nondestructive Examination – General

Testing is to be performed in accordance with a recognized Standard and the procedures, together with acceptance/rejection criteria are to be submitted to the Classification Society for review. Operators are to be appropriately qualified, in the method of inspection, to at least level II in accordance with a recognized Standard such as ISO 9712, SNT-TC-1A, EN 473 or ASNT Central Certification Program.

9.5 Magnetic Particle Inspection (MPI)

Magnetic particles shall be employed to examine the flash welded area, including the area gripped by the clamping dies. Procedures and equipment in accordance with those approved shall be used.

Frequency of examination shall be every link. Additionally, 10% of links are to be tested on all accessible surfaces. The examination room/area should be appropriately illuminated and the chain should be positioned to have good access to all surfaces.

Eddy Current (EC) testing can be considered subject to approval by ABS.

9.7 Ultrasonic Testing (UT)

Ultrasonics shall be employed to examine the flash weld fusion. Procedures and equipment in accordance with those approved shall be used. On-site calibration standards for chain configurations shall be approved. Frequency of examination shall be every link.

The flash weld shall be free from defects causing ultrasonic back reflections equal to or greater than the approved calibration standard.

11 Retest, Rejection and Repair Criteria

11.1 Measurement of Five Links

If the length of the proof loaded chain over five links is short, the chain may be stretched by loading above the proof test load specified in Section 3, Table 1, provided that:

- The load is not greater than that qualified in Subsection 1/5
- Only random lengths of chain require stretching
- The permanent deformation on studless chain is no greater than 2.5%

If loading is required to stretch the chain, the final load and the chain length identification should be noted on the inspection report. Special written approval is required in advance of chain manufacture where alterations to this procedure are required

If the length exceeds the specified tolerance, the overlength chain links shall be cut out and 4/11.3 shall apply.

11.3 Replacement of Defective Links

If single links are found to be defective or to not meet other applicable requirements, defective links may be cut out and a connecting common link inserted in their place. The individual heat treatment and inspection procedure of connecting common links is subject to ABS approval. Other methods for repair are subject to the written approval by ABS and the end purchaser.

The use of connecting accessories (such as joining shackles, detachable connecting links, etc.) or connecting common links (splice links) to replace defective links is subject to the written approval of the end purchaser in terms of the number and type permitted. The use of connecting common links (splice links) is restricted to three links, on the average, in each 100 m (330 ft) of chain.

11.5 Surface Defects

If a crack, cut or defect in the flash weld zone, or any other region, is found by visual or magnetic particle examination, it shall be ground down no more than 5% of the link diameter in depth and streamlined to provide no sharp contours. The theoretical cross sectional area of the link in way of the ground repair is not to be less than the theoretical cross section of the nominal chain diameter and the final dimensions must still conform to the agreed standard.

Ground and blended links are to be subjected to magnetic particle or dye penetrant examination. Chain links are to be removed when they are found to contain defects exceeding 5% of the link diameter in depth.

11.7 Volumetric Defects

If indications of interior of flash weld defects, in reference to the accepted calibration standards, are detected during ultrasonic examination, 4/11.3 shall apply.

11.9 Geometrical or Tolerance Failure

If link diameter, length, width, and stud alignment do not conform to the required dimensions, these shall be compared to the dimensions of 40 more links; 20 on each side of the affected link. If a single particular dimension fails to meet the required dimensional tolerance in more than two (2) of the sample links, all links shall be examined. 4/11.3 shall apply.

11.11 Break Load Test Failure

If a break load test fails, a thorough examination with the Surveyor informed in a timely manner is to be carried out to identify the cause of failure. Two additional break test specimens representing the same sampling length of chain are to be subjected to the break load test. Based upon satisfactory results of the additional tests and the results of the failure investigation, it will be decided what lengths of chain can be accepted. Failure of either or both additional tests will result in rejection of the sampling length of chain represented and 4/11.3 shall apply.

If indications are found in the flash butt weld zone that are not identified as cracks and have been found to be also present before the break test, a report is to be submitted explaining the reason for the indications together with an engineering assessment. If it is satisfactorily proven to ABS that the indications are not detrimental to the chain performance, then the requirement to carry out two additional break tests may be reconsidered.

11.13 Proof Load Test Failure

If a link fails during proof load testing, a thorough examination/failure investigation, with the Surveyor informed in a timely manner, is to be carried out to identify the probable cause of failure of the proof test. In the event that two or more links in the proof loaded length fail, that length is to be rejected. The above failure investigation is to be carried out with consideration to all factors or conditions thought to be causal to failure. Depending upon the results of the investigation, further consideration may need to be given to other lengths of chain produced.

11.13.1 Additional Break Load Tests

In addition to the above failure investigation, a break test specimen is to be taken from each side of the one failed link, and subjected to the breaking test. Based upon satisfactory results of both break tests and the results of the failure investigation, it will be decided what length of chain can be considered for acceptance. Failure of either or both breaking tests will result in rejection of the same proof loaded length.

Replacement of defective links is to be in accordance with 4/11.3.

11.15 Tensile Test Failure

Retest requirements for tensile tests are to be in accordance with 2/3.5.4(a). Failure to meet the specified requirements of either or both additional tests will result in rejection of the sampling length of chain represented and 4/11.3 shall apply.

Alternatively, reheat treatment of the rejected length or the entire chain length may be considered.

11.17 Charpy Test Failure

Retest requirements for Charpy impact tests are to be in accordance with 2/3.5.4(b). Failure to meet the requirements will result in rejection of the sampling length represented and 4/11.3 shall apply.

Alternatively, reheat treatment of the rejected length or the entire chain length may be considered.

13 Marking

13.1 Locations for Marking of Chain

The chain is to be clearly marked on the following places:

- For stud link – On the stud
- For studless – On the straight length on the side opposite the flash butt weld
- At each end of the chain length
- At intervals not exceeding 100 m (330 ft)
- Each connecting common link (splice links)
- Each link next to shackles or connecting common links (splice links)
- At first and last common link of each steel heat

All marked links shall be stated on the certificate, and the marking shall make it possible to recognize leading and tail end of the chain. In addition to the above required marking, the first and last common link of each individual charge used in the continuous length shall be traceable and adequately marked.

The marking shall be permanent and legible throughout the expected lifetime of the chain.

13.3 Markings

For stud link chain, the stud of each link identified above is to contain the following information. For studless chain, the outer straight length on the side opposite the flash butt weld of each link identified above is to contain the following information.

- The number of the certificate (furnished by the Surveyor), e.g., 96 ST 1234
- The mark signifying that the chain has been satisfactorily tested to ABS requirements and the grade as applicable, i.e., **AB/R3**, **AB/R3S**, **AB/R4**, **AB/R4S**, or **AB/R5**
- The ABS Stamp
- The manufacturer name or trademark and the nominal chain diameter in millimeters or inches (when the chain manufacturer embosses the information in a permanent manner by some suitable means such as forging or casting, marking may be omitted)
- Each connecting common link (splice link) is to have a unique identifying marking.

The Certificate number may be exchanged against an abbreviation or equivalent. If so, this shall be stated in the certificate.

13.5 Chain Certificate

Individual certificates are to be issued for each length of chain not containing an accessory. ABS's certification of mooring chain to this Section applies only to the individual lengths of chain and does not include accessories, which are certified separately. The chain certificate is to contain information on the number and location of connecting common links (splice links).

The certificate number and replacement link number may be exchanged against an abbreviation or equivalent. If so, this shall be stated in the certificate.

15 Manufacturer's Documentation

A complete Chain Inspection and Testing Report in booklet form shall be provided by the chain manufacturer for each continuous chain length. This booklet shall include all dimensional checks, test and inspection reports, NDT reports, process records, photographs (e.g., for test failures and retests and for other subjects of documentary interest, such as break loaded samples) as well as any nonconformity, corrective action and repair work. All accompanying documents, appendices, and reports shall carry reference to the original certificate number.

The manufacturer will be responsible for storing, in a safe and retrievable manner, all documentation produced for a period of at least 10 years.



SECTION 5 Testing and Inspection of Accessories

1 General

1.1 Accessory Manufacturing Process

Offshore mooring chain accessories shall be manufactured in accordance with the approved manufacturing process.

1.3 Accessory Manufacturing Process Records

Records of processing and heat treatment shall be made available for inspection by the Surveyor.

After final heat treatment, all accessories are to be subjected to proof load tests, sample break load tests, and sample mechanical tests in the presence of a Surveyor. Where the manufacturer has a procedure to record proof loads and the Surveyor is satisfied with the adequacy of the recording system, he need not witness all proof load tests. The Surveyor is to satisfy himself that the testing machines are calibrated and maintained in a satisfactory condition. Prior to testing and inspection, the chain accessories are to be free from scale, paint, or other coating.

3 Proof and Break Load Tests

Proof load and break load tests are to represent the installed configuration.

3.1 Proof Load Test

All accessories are to be subjected to the proof load specified for the corresponding stud link chain, even if the accessories are intended for studless chain.

For test details and loads, refer to Section 3, Table 1.

Proof loading of accessories with large safety factors with regard to strength will be considered on a case-by-case basis.

3.3 Break Load Test

Chain accessories are to be tested at the break load prescribed for the grade and size of chain for which they are intended. Each specimen shall be capable of withstanding the break load specified without fracture. It shall be considered acceptable if the specimen is loaded to the specified value and maintained at that load for 30 seconds without cracking.

At least one accessory out of every batch or every 25 accessories, whichever is less, is to be tested.

For individually produced accessories or accessories produced in small batches (less than five), and accessories that have a safety factor over two times the break load of the intended chain, alternative testing will be subject to special consideration. Alternative testing is to be approved by ABS.

For test details and loads, refer to Section 3, Table 1.

3.5 Definition of a Batch

A batch is defined as accessories that originate from the same heat treatment charge and the same heat of steel. Also refer to Subsections 2/5 and 2/7.

3.7 Accessories Subjected to Break Test

The accessories which have been subjected to the break load test are to be destroyed and not used as part of an outfit, with the exceptions given in 5/3.9.

3.9 Over-Designed Accessories

Where the accessories are of increased dimension or alternatively a material with higher strength characteristics is used, they may be included in the outfit at the discretion of ABS, provided that:

- i) The accessories are successfully tested at the prescribed breaking load appropriate to the chain for which they are intended, and
- ii) It is verified by procedure tests that such accessories are so designed that the breaking strength is not less than 1.4 times the prescribed breaking load of the chain for which they are intended.

5 Dimensions and Dimensional Tolerances

100% of accessories are to be checked for dimensions after proof load testing. The manufacturer is to provide a statement indicating compliance with the purchaser's requirements.

5.1 Dimensional Tolerances

The following tolerances are applicable to accessories:

- i) Nominal diameter: +5%, -0%
- ii) Other dimensions: $\pm 2.5\%$

These tolerances do not apply to machined surfaces, which will be indicated on the approved drawing.

7 Mechanical Tests

Accessories are to be subjected to mechanical testing as described in Subsections 2/1 (Rolled Plate), 2/2 (Rolled Bar), 2/3 (Forged Steel), and 2/4 (Cast Steel). Mechanical tests are to be taken from proof loaded full size accessories that have been heat treated with the production accessories they represent. The use of separate representative coupons is not permitted except as indicated in 5/7.7 below.

Where the strain-aging properties of the steel have been documented by sufficient testing and comparative testing demonstrates that values obtained from heat treated, proof loaded accessories are not significantly inferior to those from heat treated, non-proof loaded accessories, the mechanical tests may be carried out on heat treated accessories that are not subjected to the proof load. Acceptance criteria for heat treated, non-proof loaded accessories is to be agreed.

7.1 Test Location of Forged Shackles

Forged shackle bodies and forged Kenter shackles are to have a set of three impact tests and a tensile test taken from the crown of the shackle. Tensile tests on smaller diameter shackles can be taken from the straight part of the shackle, where the geometry does not permit a tensile specimen from the crown. The tensile properties and impact values are to meet the requirements of Section 1, Table 1 in the locations specified in Section 2, Figure 1, with the Charpy pieces on the outside radius of the crown.

7.3 Test Location of Cast Shackles

The locations of mechanical tests of cast shackles and cast Kenter shackles can be taken from the straight part of the accessory. The tensile properties and impact values are to meet the requirements of Section 1, Table 1 in the locations specified in Section 2, Figure 1.

7.5 Complex Geometry Accessories

The locations of mechanical tests of other accessories with complex geometries are to be agreed with ABS. Material properties in high stressed locations in the load path are to be represented, and in addition, consideration is to be given to representing the properties where they are expected to be worst. The tensile properties and impact values are to meet the requirements of Section 1, Table 1 in the locations specified in Section 2, Figure 1.

7.7 Individual Accessories or Small Batches

For individually produced accessories or accessories produced in small batches, (less than five), alternative testing can be proposed to ABS.

Each proposal for alternative testing is to be detailed by the manufacturer in a written procedure and submitted to ABS. It is to be established that alternative testing represents the actual accessory material properties in high stressed locations in the load path, and in addition, consideration is to be given to representing the properties where they are expected to be worst.

ABS’s decision to accept representative testing will also take into consideration the intended application and design life of the project for which the accessories are intended.

7.9 Definition of a Batch

A batch is defined as accessories that originate from the same heat treatment charge and the same heat of steel. Also refer to Subsections 2/5 and 2/7.

7.11 Test Location of Pins

Mechanical tests of pins are to be taken as per Section 2, Figure 1 from the mid length of a sacrificial pin of the same diameter as the final pin. For oval pins, the diameter taken is to represent the smaller dimension.

Mechanical tests may be taken from an extended pin of the same diameter as the final pin that incorporates a test prolongation and a heat treatment buffer prolongation, where equivalence with mid length test values have been established. The length of the buffer is to be at least equal to one pin diameter dimension which is removed after the heat treatment cycle is finished. The test coupon can then be removed from the pin. The buffer and test are to come from the same end of the pin as per Section 5, Figure 1. Also refer to 2/3.13 for heat treatment of rolled bars for pins and 2/5.5 for heat treatment of forged pins.

**FIGURE 1
Pin Heat Treatment Buffer**



9 Nondestructive Examination – After Proof Load Test

9.1 Visual and Surface Examination

After proof load testing and cleaning, all surfaces of every accessory are to be subjected to a close visual examination by the manufacturer for workmanship, circularity, and surface appearance. Special attention is to be paid to machined surfaces and high stress regions. All non-machined surfaces are to be sand or shot blasted to permit a thorough examination. Burrs, irregularities, and rough edges shall be contour ground. Accessories shall be uniform and have smooth internal radii, and are to be free from injurious surface imperfections, such as surface cracks, dents, and cuts. The examination room/area should be appropriately illuminated and the chain should be positioned to have good access to all surfaces.

On accessories only, grinding and blending repair may go beyond 5% of the accessory diameter provided the stress concentration factors do not exceed that of the common link and that the theoretical cross sectional area (CSA) of the accessory is maintained.

9.3 Nondestructive Examination – General

Testing is to be performed in accordance with a recognized Standard and the procedures, together with acceptance/rejection criteria are to be submitted to ABS for review. Operators are to be appropriately qualified, in the method of inspection, to at least level II in accordance with a recognized Standard such as ISO 9712, SNT-TC-1A, EN 473 or ASNT Central Certification Program.

9.3.1 Surface NDE

All chain accessories are to be checked by magnetic particles or dye penetrant. Procedures and equipment in accordance with those approved shall be used. The areas to be subjected to surface NDE are to include high stress areas, machined surfaces, areas of abrupt geometrical changes, and areas where defects are most likely. If MPI is used, accessories should be magnetized, if possible, in two mutually perpendicular directions. The examination room/area should be appropriately illuminated and the accessories should be positioned to have good access to all surfaces.

Eddy Current (EC) testing can be considered subject to approval by ABS.

9.3.2 Ultrasonic Examination

All chain accessories, both forgings and castings, are to be subjected to ultrasonic examination to the standard submitted and approved in connection with the qualification of the manufacturer. On-site calibration standards for chain configurations shall be approved. Frequency of examination shall be every accessory. The accessory shall be free from defects causing ultrasonic back reflections equal to or greater than the approved calibration standard.

9.5 Manufacturer's Statement

The manufacturer is to provide a statement that nondestructive examination has been carried out with satisfactory results. This statement should include a reference to the techniques and to the operator's qualification. Additional break and proof load tests are to be done.

11 Test Failures

In the event of a failure of the break or proof load test, the entire batch represented by the test is to be rejected unless the cause of failure has been determined and it can be demonstrated to the Surveyor's satisfaction that the condition causing the failure is not present in any of the remaining accessories.

In the event of mechanical test failure, tension and impact retests as permitted in 2/3.5.4 (bar), 2/5.9.2 (forgings), and 2/7.9.2 (castings) can be carried out. Failure of any mechanical retest will result in rejection of the entire lot.

Alternatively, reheat treatment of the rejected lot may be considered.

13 Marking and Certification

13.1 Marking

Each accessory is to contain the following information.

- The number of the certificate (furnished by the Surveyor), e.g., 96 ST 1234
- The mark signifying that the accessory has been satisfactorily tested to ABS requirements and the grade as applicable (i.e., **AB/R3**, **AB/R3S**, **AB/R4**, **AB/R4S**, or **AB/R5**)
- The manufacturer name or trademark and the nominal accessory diameter in millimeters or inches (when the accessory manufacturer embosses the information in a permanent manner by some suitable means such as forging or casting, marking may be omitted)
- Each accessory is to have a traceable identifying marking
- Each detachable component part is to be stamped or marked with an identifying number to avoid mixing components.
- The marking is to be permanent and legible throughout the expected lifetime of the accessory.

13.3 Certificates

Individual certificates are to be issued for each type of accessory. The accessory identification numbers are to be included on the certificate.

The Certificate number may be exchanged against an abbreviation or equivalent. If so, this shall be stated in the certificate.

15 Documentation

A complete Inspection and Testing Report in booklet form shall be provided by the manufacturer for each order. This booklet shall include all dimensional checks, test and inspection reports, NDT reports, process records, and photographs, as well as any nonconformity, corrective action, and repair work.

Each type of accessory shall be covered by separate certificates.

All accompanying documents, appendices, and reports shall carry reference to the original certificate number.

The manufacturer will be responsible for storing, in a safe and retrievable manner, all documentation produced for a period of at least 10 years.